

RULES

ASCE/AISC STUDENT STEEL BRIDGE

COMPETITION

2003

PDF Version

<http://www.aisc.org/steelbridge.html>

31 July 2002

TABLE OF CONTENTS

	<u>page</u>
I. Introduction	3
II. Executive Summary	4
III. Rule Changes	4
IV. Problem Statement	5
V. Safety	5
VI. Scoring	6
VII. Schedule of Competition	8
VIII. Dimensions and Support	8
IX. Material and Components	12
X. Construction	14
XI. Load Tests	19
XII. Equipment Provided by Host	24
XIII. Interpretation of Rules	26
XIV. Judging	26
XV. Protests and Appeals	26
XVI. Tips for Competitors	27
XVII. Score Sheet	29
 <u>Figures</u>	
Spans and Clearance	11
Deck Support, Roadway and Bearing	11
Site Plan	17
Location of Targets and Decking	20
Load Test 1	21
Load Test 2	22
Load Test 3	24

I. INTRODUCTION

The Student Steel Bridge Competition is sponsored by the American Institute of Steel Construction and co-sponsored by the American Society of Civil Engineers, the American Iron and Steel Institute, the James F. Lincoln Arc Welding Foundation, the National Steel Bridge Alliance, Nucor Corporation and TXI Chaparral Steel. This inter-collegiate challenge requires Civil Engineering students to design, fabricate and construct a steel bridge.

Safety is of primary importance. The AISC requests that competitors, hosts and judges take all necessary precautions to prevent injury.

The competition rules are changed every year to improve the contest and assure that competitors design and build new bridges.

Students design the bridge themselves but may seek advice from faculty and other consultants.

Ideally, students should fabricate the entire bridge themselves. However, appropriate shop facilities and supervision may not be available at every college and university. Therefore, the services of a commercial fabricator may be used provided that students observe the operations. Students are encouraged to maximize their personal involvement in fabricating their bridge.

There are two levels of competition: regional and national. These *Rules* govern competition at both regional and national levels. Regional competitions are held in conjunction with ASCE regional conferences. Winners and first runners-up from most regions are invited to compete at the national level. However, invitations are extended only to the winner from a region with two, three or four participating universities, and to the top three teams from a region with eleven or more participating universities. Only one bridge per university may be entered in regional competitions.

This booklet describes the contest and states the official rules for this year. It is distributed to universities throughout the country. A companion booklet, *Guide for Hosts and Judges*, is distributed to hosts and provides directions for conducting a competition.

The rules are intended to be prescriptive but may require some interpretation. The procedure for requesting clarification of the rules is described in section "XIII Interpretation of Rules."

The ASCE student chapters and clubs entering the contest are required to be current with their national dues. Teams may consist only of undergraduate and graduate students in good standing with their ASCE chapter or club.

II. EXECUTIVE SUMMARY

Civil Engineering students are challenged to an inter-collegiate competition that includes design, fabrication and construction. Participating students gain practical experience in structural design, fabrication processes, construction planning, organization and teamwork.

The “Problem Statement” describes challenges encountered in a representative structural engineering project. The competition is a scaled simulation of that project.

Standards for strength, durability, constructability, usability, functionality and safety reflect the volumes of regulations that govern the design and construction of full-scale bridges. Criteria for excellence are represented by the award categories of stiffness, lightness, construction speed, aesthetics, efficiency and economy. As with a full-scale construction project, safety is the primary concern.

The rules of the competition accommodate a large variety of designs and allow innovation. Designers must consider carefully the comparative advantages of various alternatives. For example, a truss bridge may be stiffer than a girder bridge but slower to construct.

The Student Steel Bridge Competition provides design and construction planning experience, an opportunity to learn fabrication procedures, and the excitement of competing against students from other colleges and universities.

III. RULE CHANGES

The following list covers some of the major changes from the 2002 rules. Minor changes are not listed. Contestants and judges are cautioned to read this entire *Rules* booklet carefully and disregard rules from previous years.

1. A university may enter only one bridge in regional competitions.
2. Several changes in scoring and penalties.
3. A poster is required for the regional contest.
4. No cantilevers, and the bridge will be dual span. Consequently there are changes in dimensions, construction site, deflection targets and load pattern.
5. Cables and round tubes are permitted.
6. Fasteners are standardized.
7. Limit on number of components in an assembly.

8. One builder may serve as a barge and work in the river. However, a temporary pier is not permitted.
9. Restriction on handling multiple members and assemblies.
10. A new schedule limits changes made to a bridge during competition.

IV. PROBLEM STATEMENT

A century-old bridge that crosses an environmentally sensitive river must be replaced. The bridge carries truck traffic serving the farms and agricultural processing industries that are the basis for the economy of this rural region, as well as providing access and emergency services to residences. A quick replacement is necessary because no other river crossing is available for miles.

The State Department of Transportation has requested design/build proposals for replacing the existing bridge. Any appropriate type of bridge will be considered but the State DOT has specified steel as the material because of its durability and fast erection. The bridge must provide clearance for flood flows and it must be able to carry specified patterns of loads without exceeding sway and deflection limits. Based on past experience with performance and maintenance, the DOT prefers bridges that are relatively light and stiff, with low profiles. The new bridge must accommodate modular decking, which the DOT salvaged from another bridge. Decking units may not be modified.

Flood control and environmental concerns prohibit piers in the river; piers must be built on the banks and on a natural island that is connected to the river bank by an existing causeway. A construction barge may be operated within a designated section of the river but must not disturb the river banks, causeway or island. Soil conditions restrict the weight that may be lifted by cranes.

Your company's design/build proposal is among those that the State DOT has deemed responsive. The DOT has asked each competing firm to submit a 1:10 scale model to demonstrate its concept. Models will be erected under simulated field conditions and then load tested. The DOT will evaluate the models by multiple criteria including durability, constructability, usability, stiffness, construction speed, efficiency, economy and aesthetics. The contract will be awarded to the company that submits the best model. This is an opportunity to become leaders in the bridge replacement market.

V. SAFETY

Safety has the highest priority. Judges are empowered to halt any activity that they deem hazardous. Judges are directed to disqualify bridges that cannot be safely constructed or load tested using the equipment provided by the host, as described in this booklet. Collapse, sway or deflection in excess of specified limits is incontrovertible evidence of an unsafe bridge and will result in disqualification. A

disqualified bridge is not eligible for awards in any category and must be withdrawn from all subsequent participation in the contest.

VI. SCORING

A university may enter only one bridge in regional competition and may compete in only one region.

Categories of competition are construction speed, lightness, aesthetics, stiffness, construction economy, and structural efficiency. In addition, overall performance is rated. Bridges that have been disqualified are not eligible for awards in any categories.

A. Construction Speed

The bridge with the lowest construction time will win in this category. Construction time is the clock time required to assemble the bridge, regardless of number of builders, plus time penalties prescribed in sections “X.G Construction: Accidents” and “XI.B Load Tests: Damage.”

B. Lightness

The bridge with the least total weight will win in the lightness category. Total weight is the weight of the bridge plus weight penalties prescribed in sections “VIII.B Dimensions and Support: Usability” and “IX.B Material and Components: Durability and Constructability.” Decking, tools and poster are not included in total weight.

C. Aesthetics

The full name of the college or university must appear on the bridge or on a banner or placard attached to the bridge, in letters at least 2 inches high. The banner or placard is included in total weight but need not be installed during timed construction. It should be in place on the bridge during aesthetics judging and at other times when the bridge is on display.

Every bridge must be accompanied by a poster illustrating and briefly describing design and fabrication processes. Maximum dimensions of the poster are 2 feet by 3 feet, and it should be designed to be displayed within the floor area occupied by the bridge. The poster is not part of the bridge but should be in place during aesthetics judging and at other times when the bridge is on display.

In addition to the college or university name and the poster, other factors that may be considered include general appearance, balance and proportion of the design, elegance, and finish. Quality of fabrication should not be considered because some bridges may be fabricated professionally while others are student work.

Aesthetics is the tie-breaker for overall performance and for all other categories of competition. Judges should not declare ties in aesthetics.

D. Stiffness

The bridge with the lowest aggregate deflection will win in the stiffness category. Aggregate deflection is determined from measurements as prescribed in section "XI Load Tests."

E. Construction Economy

The bridge with the lowest construction cost (C_C) will win in the construction economy category. Construction cost is computed as

$$C_C = \text{Construction time (minutes, including penalties)} \\ \times \text{Number of builders (persons)} \times 100 \text{ (thousand \$ / person-minute)}$$

The number of builders includes all participants who are within the construction site at any time during timed construction.

F. Structural Efficiency

The bridge with the lowest structural cost will win in the structural efficiency category. Structural cost (thousand \$) is computed as

$$C_S = W \times \Delta \times D, \text{ where}$$

W = the larger of total weight OR 100 pounds.

Δ = the larger of aggregate deflection OR 1.000 inch.

D = the largest of maximum height of bridge minus 18 inches

OR 18 inches minus minimum clearance OR 24 inches.

Total weight is the weight of the bridge plus weight penalties prescribed in sections "VIII.B Dimensions and Support: Usability" and "IX.B Material and Components: Durability and Constructability." Decking, tools and poster are not included in total weight.

Aggregate deflection is determined from measurements as prescribed in section "XI Load Tests."

Maximum height of the bridge is the vertical distance (in inches) from the ground or river surface to the highest point on the bridge structure (not including decking).

Minimum clearance is the vertical distance (in inches) from the river to the lowest point on the bridge over the river.

G. Overall Performance

The overall performance rating of a bridge is the sum of construction cost and structural cost ($C_C + C_S$). The bridge achieving the lowest value of this total wins the overall competition.

VII. SCHEDULE OF COMPETITION

In the months before the contest students design their bridges, fabricate members, load test and practice erection. Elements of the competition are:

1. Judges clarify rules and conditions of the contest and answer questions.
2. If judges permit minor alterations to be made to the bridges, the contest should not be delayed significantly and teams should be given equal time for alterations. After this, bridges may not be altered, modified or enhanced in any way (except for erection, disassembly and repairs as described in section "X.I Construction: Repairs").
3. Bridges are erected and judged for aesthetics.
4. The head judge selects the locations of vertical deflection targets. See section "XI.C Load Tests: Preparation" for explanation of deflection targets. Selection is done in the presence of the team captains by rolling a die twice. The first roll determines which of the locations L1 through L6 will be used; the second roll determines which of the locations S1 through S6 will be used. The head judge also uses a random process to select the side of the bridges to which the lateral load will be applied during load testing.
5. Timed construction. See section "X Construction" for details.
6. Load testing. See section "XI Load Tests" for details.

The national contest will be conducted in the order shown above, with several bridges being constructed simultaneously, while other completed bridges are being load tested. A different schedule may be better for regional contests with few entries. However, it is essential that

1. bridges are not modified after selection of target locations,
2. bridges are not modified between aesthetics judging and timed construction, and
3. modifications between timed construction and load testing are limited to repairs as described in "X.I Construction: Repairs."

VIII. DIMENSIONS AND SUPPORT

Dimensions and support will be checked with the bridge in its as-built condition after construction is completed and before the bridge is moved from the construction site. The bridge may not be modified nor distorted from its as-built condition in order to satisfy dimension and support rules. Dimensions will be checked without decking or other load on the bridge.

A. Functionality and Safety

If any of the following regulations in this section (VIII.A) is violated, the bridge must be **disqualified**. The figures titled “Spans and Clearance” and “Deck Support, Roadway and Bearing” illustrate some of the requirements. The first and second regulations will be verified by sliding a piece of decking or an equivalent template along the full overall end-to-end length of the decking support.

1. The bridge must provide continuous rigid support for the decking along both of the edges that run in the longitudinal direction of the bridge. The decking support must be at least 23 feet long, and it must be rigid and continuous in plan view. Also see paragraphs VIII.B.2 and 12. Horizontal cables do not provide rigid support.
2. The bridge must provide access for placing the decking and load. Although decking is nominally 3’6” wide and 1 inch thick, actual widths range from 3’5.25” to 3’6.75” and thickness may be as large as 1.25 inches. Also see paragraph VIII.B.9 and 13.
3. The decking may not be attached nor anchored to the bridge, nor may it be used to distort the bridge from its as-built condition. However, judges may clamp the decking to the bridge to facilitate deflection measurements as explained in section “XI Load Tests.”
4. The bridge may not be anchored nor tied to the ground.
5. It must be possible to construct and load the bridge safely using equipment provided by the host university. Bridges must accommodate local conditions.

B. Usability

A penalty will be assessed for each rule in this section (VIII.B) that is violated, rather than for every violation of that rule. The figures titled “Spans and Clearance” and “Deck Support, Roadway and Bearing” illustrate some of the requirements.

The penalty for violation for each of the following rules will be an addition to the weight of the bridge determined as follows: 100 pounds for a dimensional violation of 1.0 inch or less; 300 pounds for a dimensional violation greater than 1.0 inch but not exceeding 2.0 inches; 600 pounds for a dimensional violation greater than 2.0 inches but not exceeding 3.0 inches. The bridge must be **disqualified** if a dimensional violation exceeds 3.0 inches.

1. The bridge must span both parts of the river without touching it. No part or accessory of the completed bridge may touch the river. One part of the river is 14’0” wide and the other is 7’0” wide.
2. The decking support may not be longer than 25’0”. Also see paragraph VIII.A.1.

3. No part of the bridge (including fasteners and bearing plates) may extend beyond either end of the decking support.
4. At completion of timed construction, the bridge must bear on the river banks and on the island. See the figure titled "Site Plan" for size and location of the island.
5. The entire bridge must be located on the island side of the reference line. See the figure titled "Site Plan" for location of the reference line.
6. A rectangular floodway must be provided under the bridge. The floodway must be at least 1'0" high at all points over the river, measured from the surface of the river, and it must extend from one bank to the edge of the island and from the other edge of the island to the other bank. The floodway must traverse the entire width of the bridge.
7. At each point where it bears on the ground the bridge will include a solid bearing plate at least 1/4 inch thick, at least 2 inches long and at least 2 inches wide. In plan view, a bearing plate may be any shape into which a 2 x 2 inch rectangle may be inscribed. Bearing plates must be smooth and flat on the bottom. Bearing plates are part of the bridge.
8. On the island and on each river bank the bridge must bear on the ground over a width of at least 3'6" measured from the outside edges of the bearing plates. Bearing is not required to be continuous over that width.
9. A vehicle passageway at least 3'0" wide must completely traverse the bridge from end to end, and must extend upward from the decking through the top of the bridge for the full length of the bridge. That is, a vehicle that is 3'0" wide and infinitely high should be able to cross the bridge. Also see paragraph VIII.A.2.
10. No part of the bridge may extend more than 5'0" above the ground or river surface, which have the same elevation.
11. The top surface of the decking supports must be no less than 1'5" nor more than 1'8" above the surface of the ground and river at any point. Note that the surfaces of the ground and river have the same elevation.
12. Decking must be supported without overlaps, longitudinal discontinuities, abrupt elevation differences or protrusions exceeding 1/4 inch. Also see paragraph VIII.A.1.
13. Clear span of the decking between decking supports should not exceed 3'4". Also see paragraph VIII.A.2.
14. The edges of the decking that run in the longitudinal direction of the bridge may be cantilevered over their supports no more than 6 inches on each side.

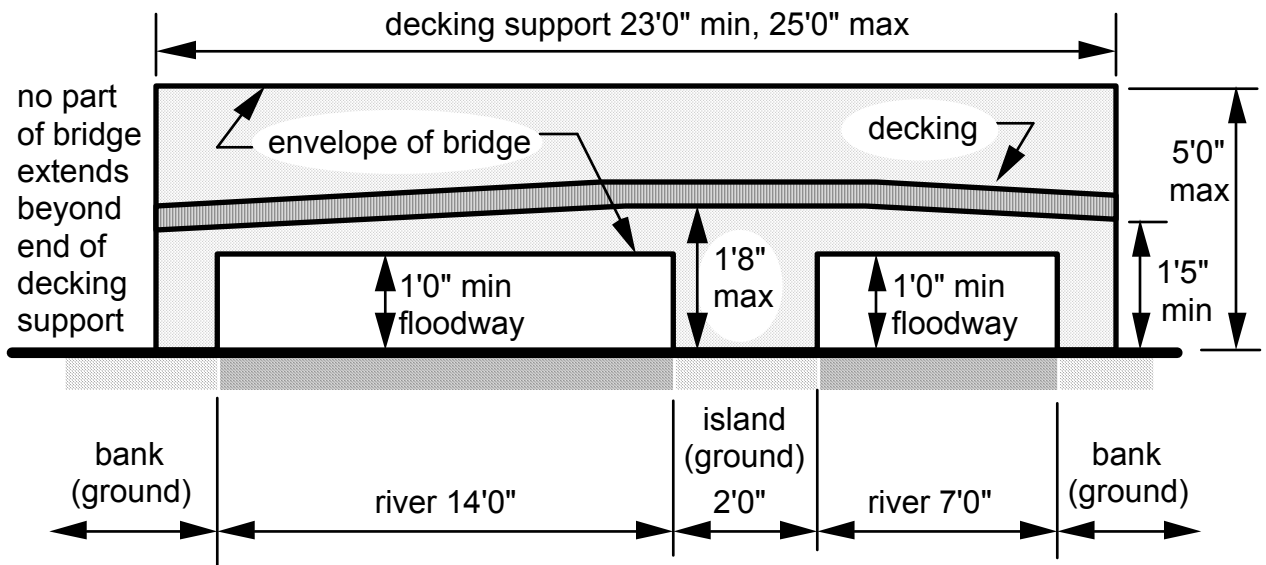

Spans and Clearance (Side View)

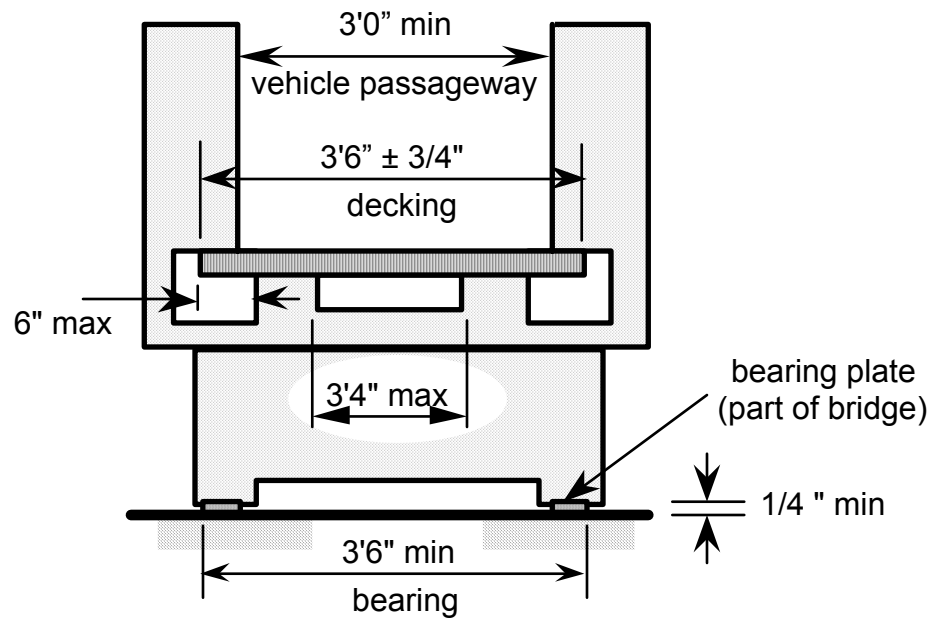

Deck Support, Roadway and Bearing (End View)

IX. MATERIAL AND COMPONENTS

A. Safety

If any one of the following regulations in this section (IX.A) is violated, the bridge must be **disqualified**.

1. A rigid member or cable with fittings may not weigh more than 40 pounds. See section IX.B for definitions of “rigid member” and “cable with fittings.”
2. A bridge may not incorporate an electric, electronic, fluidic or other non-mechanical sensor or control system; a non-mechanical energy transmission device such as a wire, duct or tube; an energy conversion or storage device such as a motor, electromagnet, hydraulic or pneumatic piston, turbine, chemical reactor, pressure vessel, pre-loaded spring or electric cell.
3. Energy may not be transmitted to or from a bridge (for example, by applying mechanical, magnetic, fluidic or other force; by sound, light radio or other wave or ray; by conduction or convection of heat; or by electric current). The exceptions are forces necessary to the competition (for example, those associated with load testing and with moving the bridge from place to place), and changes in ambient conditions that are not controlled by contestants (such as wind, temperature and lighting).

B. Durability and Constructability

Violation of the following rules in this section (IX.B) will result in weight penalties being added to the weight of the bridge. The penalty for each violation is 10 pounds plus 5 times the weight of the non-conforming components.

1. A bridge may be constructed only of structural steel. For the purposes of this contest, structural steel is defined as an iron alloy that is strongly attracted to a magnet. Exceptions: Paint, banners, placards and other purely decorative items.
2. A bridge may be constructed only of components conforming to the following definitions:
 - a. A rigid member is a steel component that retains its shape and dimensions during timed construction and in the completed bridge. Paragraphs IX.B.3 - 6 govern rigid members.
 - b. A cable with fittings is a flexible steel component that retains its length during timed construction and in the completed bridge. A fitting is a rigid steel part of a cable with fittings, and is necessary at connections to rigid members or to other cables with fittings. Paragraphs IX.B.7 - 14 govern cables with fittings.

- c. A fastener is a steel bolt with at least one steel nut. Paragraphs IX.B.15 and 16 govern fasteners.
- d. An assembly consists of no more than four rigid members and/or cables with fittings plus any number of fasteners that are connected together in the staging yards during timed construction. Paragraphs IX.B.17 and 18 govern assemblies.
3. A rigid member may not exceed overall dimensions of 3'6" x 6" x 6." That is, it must fit in a prismatic box of those dimensions.
4. A rigid member must retain its shape, dimensions and rigidity during timed construction and load testing. Hinged, jointed, articulated and telescoping members are prohibited, as are those with parts that move. This prohibition includes members with parts that are intended to slide, rotate, deflect or bend relative to the member such as cams, latches, sliding pins, springs, and snap-lock devices. Also prohibited are members incorporating hinges or other devices that do not restrain rigid-body rotation or translation of one part of the member relative to another. Exception: Deformations caused by mechanical strain (i.e. bending, stretching) during load testing are not considered violations of this rule.
5. A rigid member may consist of several parts rigidly joined together (e.g. welded, bolted, screwed) before timed construction begins. Those parts must remain rigidly joined throughout the construction process and in the completed bridge.
6. Each rigid member must be connected directly to every other rigid member and/or cable with fittings that it touches by at least one fastener installed during timed construction so that the connection cannot be taken apart without first removing a nut from the bolt. The bolt must penetrate completely through a round hole in each of the rigid members and/or cables with fittings that it connects.
7. A cable with fittings must be capable of being coiled to a six-inch diameter and then uncoiled without damage.
8. The cross-section of the flexible part of a cable with fittings (i.e. the cable) must be nearly circular.
9. The flexible part of a cable with fittings (i.e. the cable) must not be in direct contact with any part of a fastener in the completed bridge.
10. A fitting (i.e. a rigid part of a cable with fittings) may not exceed 2" in any linear dimension.
11. A cable with fittings may have any number of fittings and ends.
12. The length of a cable with fittings may not exceed 20'0". The length of a branched (i.e. more than two ends) cable with fittings is the total of the lengths of all branches.

13. Cables with fittings may include steel turnbuckles and other devices for adjusting lengths prior to timed construction. Turnbuckles or other devices may not be adjusted during or after timed construction.
14. A cable with fittings may consist of several parts joined together before timed construction begins. Those parts must remain joined throughout the construction process and in the completed bridge.
15. The bolt in a fastener must be 3/8" nominal diameter and no more than 3" nominal length (bottom of head to end) with a hexagonal head, and it must have the configuration and dimensions of a "hex cap screw" or "tap bolt" illustrated on <http://www.americanfastener.com/techref/capscrew.htm>. Bolts may not be altered or modified in any manner.
16. The nuts in a fastener must match the bolt. That is, the nominal size (inside diameter) must be 3/8" and the threads of the nuts must engage the threads on the bolt and permit the nuts to be turned onto the bolt. Nuts must be hexagonal and have the configuration and dimensions of "finished hex nuts," "heavy hex nuts," or "hex machine screw nuts" as illustrated on <http://www.americanfastener.com/techref/nuts.htm>. Nuts may not be altered or modified in any manner.
17. An assembly may consist of no more than four rigid members and/or cables with fittings.
18. The components of an assembly must remain connected.

X. CONSTRUCTION

A. Safety

If any of the following safety regulations is violated during timed construction, the judge will stop the clock and explain the violation. Before restarting the clock, builders, tools and bridge components will be returned to the positions they occupied before the violation. Then the builders will be asked to resume construction using safe procedures. A bridge that cannot be constructed safely must be **disqualified**.

1. Builders must not be exposed to risk of personal injury.
2. Nothing may be thrown. Also see paragraph X.G.1.
3. Only tools that are hand-held during use are permitted. Field welding and tools requiring external power connections are prohibited. Tools may not be used to support or elevate builders.
4. All builders must wear hardhats and safety glasses or goggles during timed construction.

5. A builder may not use the bridge, a portion of the bridge, or a tool to support the builder's body weight. For example, lying, standing, sitting or kneeling on those objects is prohibited. However, a builder may lean on the bridge if the builder is kneeling on one or both knees or if the builder is standing on the heels and toes of both feet.

6. A builder may not depend on another builder or builders for support or balance.

7. A builder may not cross either part of the river by jumping, by temporary scaffolding, by crossing the bridge, or by any other means. Exception: the builder who is designated as the barge may walk on the river.

8. Outside the staging yard, a builder may contribute to lifting, carrying or supporting only one rigid member, or one cable with fittings, or one assembly at a time.

9. Outside the staging yard, moving an assembly requires the effort of at least as many builders as there are rigid members and/or cables with fittings in that assembly. The word "moving" includes, but is not limited to, lifting, carrying, lowering, rolling, turning, sliding and tipping, as well as causing translation and/or rotation of one portion of the bridge relative to another. Exception: small movement (maximum 3 inches) of a portion of the bridge or of the entire bridge by as few as one builder will be allowed as necessary to facilitate connections and placement on the site.

10. Outside the staging yard, any portion of the bridge that is not moving must either be supported by as many builders as there are rigid members and/or cables with fittings in that portion of the bridge, or must be supported without the assistance of builders by the portion itself and/or other portions of the bridge.

B. Team

Participation is limited to undergraduate and graduate student members of an ASCE chapter or club or similar invited organization. The construction team, also referred to as builders, consists of all participants who are within the construction site at any time during timed construction. There can be no more than ten participants on the construction team.

The team captain may designate one builder to be a barge. This builder will operate only in the river from start to finish of timed construction.

C. Tools and Safety Equipment

Competitors provide their own tools, hardhats and safety glasses or goggles. See paragraphs X.A.3 and 4.

D. Construction Site

See the figure titled "Site Plan" for layout of the construction site.

The reference line is provided to guide construction. It is perpendicular to the banks of the river, extends from bank to bank and separates the island from the causeway.

The island and river banks (i.e. places on which the bridges will bear) should lie in a common plane. If the island and river banks deviate from a common plane by more than $\pm 1/4$ " the host must adjust the elevations of the island and river banks to within that tolerance using steel plates, plywood or other flat, solid materials. Before timed construction team captains may use a string line to verify that the river banks and island are sufficiently coplanar and may improve planarity with material they supply.

Only builders and judges are permitted in the construction site during timed construction. Only judges are permitted near the construction site; coaches, managers and other spectators must observe from a safe distance that does not obstruct judges.

E. Start

Before construction begins, all of the following items, and nothing else, are in the staging yards: rigid members, cables with fittings, fasteners, tools and builders except for the barge. If a builder has been designated to be the barge, that builder and nothing else will be in the river. Builders will be wearing hardhats and safety glasses or goggles, as well as optional clothing such as pouches. Rigid members, cables with fittings, tools and fasteners must be on the ground. Rigid members and cables with fittings must not be connected nor in contact with one another. Each cable with fittings must be coiled to an approximate diameter of 6". Tools and fasteners must not be in contact with rigid members or with cables with fittings.

During timed construction, no additional rigid members, cables with fittings, fasteners, tools or builders may be brought into the construction site nor may anything be removed from the construction site.

Timing and construction begin when the builders signify that they are ready and the judge declares the start.

F. Time

Time is kept from start to finish of construction. The clock will be stopped:

1. if a builder or judge sees a condition that could cause injury, or
2. when a safety regulation has been violated or work has been accomplished by committing an "accident." See sections X.A and G.

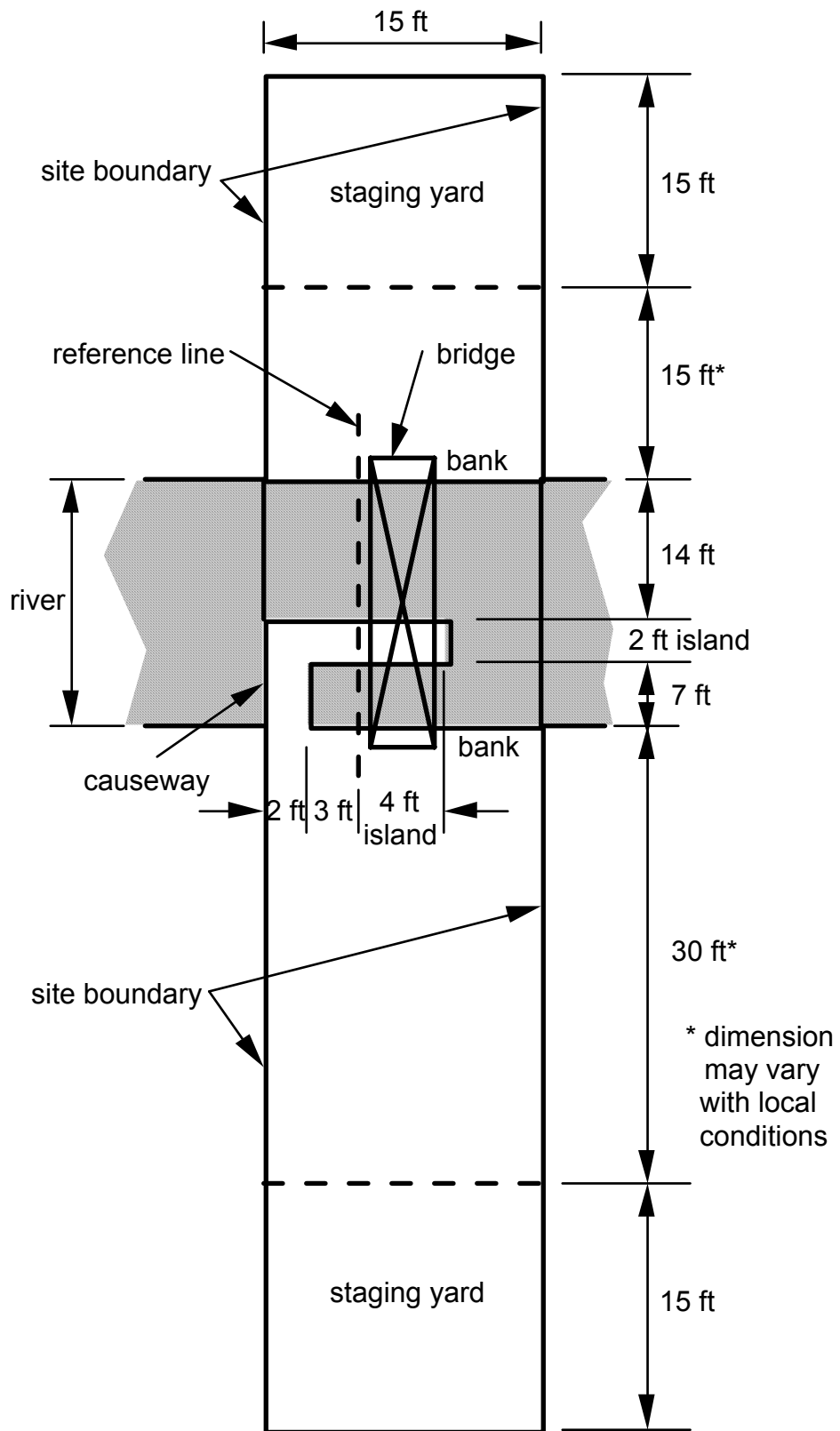

Site Plan

Construction ceases while the clock is stopped. The clock is restarted after the situation has been corrected.

G. Accidents

In general, the clock is not stopped when an “accident” occurs. If an accident is continuous (for example, a builder stands in the river) it will be counted as multiple incidents. Builders involved in accidents may continue to build, and components involved in accidents may be recovered and used.

Construction cannot depend on deliberately committing an accident. Therefore, the clock will be stopped if any work is accomplished by committing an accident. Before resuming timed construction, the builders, tools, rigid members, cables with fittings and fasteners will be returned to the positions they occupied before the accident.

Types of accidents and the corresponding time penalties, which will be added to the construction time, are:

1. A builder throws something. Penalty is one minute (60 seconds) per incident. Also see paragraph X.A.2.
2. A builder, other than the one designated as a barge, touches the river. Penalty is 1/2 minute (30 seconds) per incident. Exception: Builders may step in the river without penalty to retrieve a dropped member, tool, nut, bolt or hardhat.
3. The builder designated as the barge (if there is one) touches the river bank, island or causeway. Penalty is 1/2 minute (30 seconds) per incident.
4. The builder designated as the barge crosses the island or causeway, for example by stepping or jumping across. Penalty is 1/2 minute (30 seconds) per incident.
5. A rigid member, cable with fittings or portion of the bridge touches the river or the ground outside a staging yard. Penalty is 1/3 minute (20 seconds) per incident. Exception: No penalty is assessed when the ground is touched by the bottom of a bearing plate that will bear on the island or river bank when the bridge is completed. Also see paragraph VIII.B.7.
6. A tool, nut, bolt or hardhat touches the river or the ground outside a staging yard. Penalty is 1/6 minute (10 seconds) per incident. Exception: a tool used exclusively for measuring may touch the ground during use while being held by a builder.
7. A builder steps outside the boundary of the construction site. Penalty is 1/6 minute (10 seconds) per incident.

H. Finish

Construction ends when the bridge has been completed by connecting all the rigid members and cables with fittings, all tools and builders are back in the staging yards (except the barge, which remains in the river), and the builders signify that they are finished. Installation of decking is not included in timed construction.

After construction is finished the bridge may not be modified except as provided by section "X.I Construction: Repairs."

I. Repairs

Before the judges inspect and measure the bridge and before the bridge is moved from the construction site, the builders will be given the opportunity to examine the bridge for construction mistakes. The team will be permitted, but not required, to repair these mistakes. Repairs are made with the clock restarted. Safety precautions (section X.A) apply and accidents (section X.G) are counted. The time required to make repairs is multiplied by 1.5 and added to the original construction time. Violations of sections VIII and IX will not be penalized if they have been repaired successfully.

XI. LOAD TESTS

A. Safety Precautions

The judge will halt any activity that is hazardous.

A bridge could suddenly collapse or sway in any direction during load tests. Therefore, minimize the number of people near the bridge while it is being tested. Usually, the load may be placed on the bridge by only two competitors.

While participating in load testing, **competitors must wear hardhats, safety glasses or goggles, gloves and leather construction boots**. This safety equipment is provided by the competitors. Similar equipment is recommended for judges who will be near the bridge during load testing.

During testing, safety supports must be in place below the bottom of the decking. The safety supports should be of sufficient height, strength, number and extent that none of the load will fall more than four inches if the bridge collapses.

Do not exceed 400 psf uniform load or 500 pounds concentrated load on the decking. Do not load on a portion of the decking that is cantilevered laterally over its support.

When any portion of the load is on the bridge, no one is permitted to crawl, reach or step under the bridge. If such an action is necessary, the load must first be removed.

B. Damage

A bridge will not be tested in a condition that compromises its strength or stability.

If a nut falls off its bolt while the bridge is being transported or prepared for load testing, the connection will be repaired, the nut will be replaced (finger tight) and a penalty of 2 minutes will be added to construction time.

A bridge with irreparable damage that would reduce its strength or stability (such as a broken part) will be **disqualified** and will not be load tested.

C. Preparation

The floor surfaces on which the bridges will bear should lie in a common plane. If the floor is not flat to within $\pm 1/4"$, adjust the elevations of the island and river banks to within that tolerance with steel plates or steel shims under the bearing plates of the bridge. If a team requires a closer tolerance they are permitted to make finer adjustments using steel plates, sheets or shims that they provide. Plates, sheets or shims may not be used to compensate for imprecise construction or fabrication of the bridge.

Sway is translation in any horizontal direction. Two targets are established for sway measurements: one is near the center of the longer span, and the other is near the center of the shorter span as illustrated in the figure titled "Location of Targets and Decking". Sway targets are on the side of the bridge determined at the beginning of the competition (section "VII Schedule of Competition").

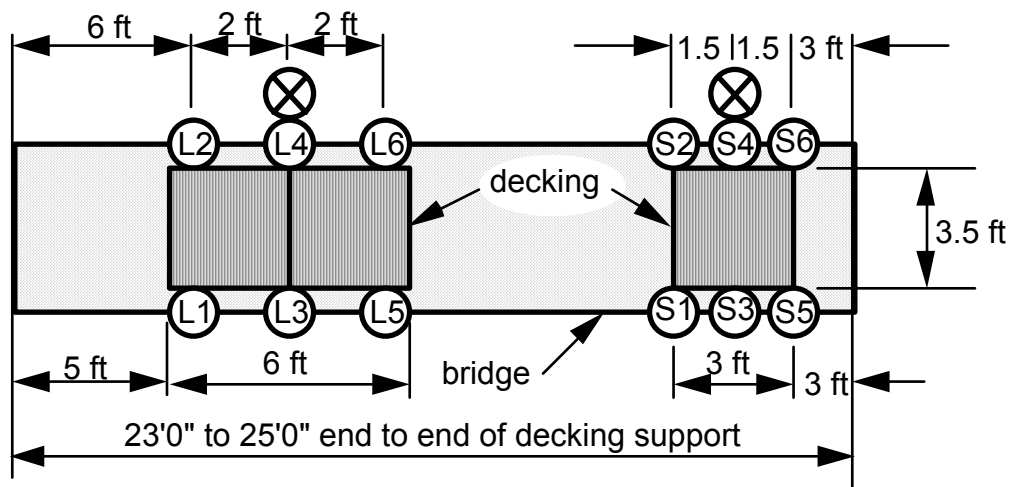

L1 through L6 and S1 through S6 are possible locations for vertical deflection targets. Only one L and one S are used (section VII).

⊗ targets for measuring sway

Location of Targets and Decking (Plan)

Two targets are established for measuring vertical deflection. One target is at one of the locations L1 through L6 on the longer span; the other target is at one of the locations S1 through S6 on the shorter span as illustrated in the figure titled "Location of Targets and Decking". These locations were determined at the beginning of the competition (section "VII Schedule of Competition"). Vertical deflection targets are located at the level of the top of the decking support, which is the same as the bottom of the decking. Targets may be on the decking or on the decking support.

At their discretion judges may impose a penalty for a bridge that incorporates parts having the primary function of interfering with placement of targets or measuring equipment.

Teams must accept imperfect field conditions such as bent decking.

Safety supports are placed under the level of the decking so that no portion of the load will drop more than four inches if the bridge collapses.

A BRIDGE THAT COLLAPSES DURING LOADING, DEFLECTION MEASUREMENTS OR UNLOADING MUST BE DISQUALIFIED.

D. Load Test 1 - Lateral

Load test 1 is conducted without decking but with restraint at the bearing plates to prevent the bridge from sliding or tipping. As shown in the figure titled "Load Test 1," apply a 50 pound lateral force at one of the sway targets (and on the same side), and measure the sway. Repeat the process at the other sway target. To pass load test 1, the sway must not exceed 1.0" at either sway target. If the bridge does not pass load test 1 it is disqualified; do not conduct any other load test. Remove the lateral load; it is not part of the remaining load tests.

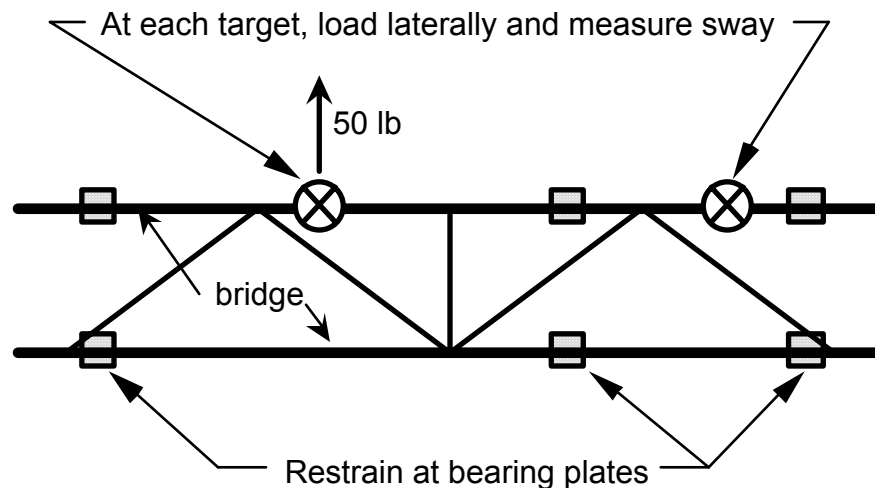

Load Test 1 (Plan)

E. Load Test 2 - Shorter Span

Place two units of decking near the center of the longer span and extending 6 feet in the span direction. Place one unit of decking near the center of the shorter span. Decking locations are illustrated in the figure titled "Location of Targets and Decking."

Position measuring devices on the two vertical deflection targets.

Uniformly distribute 500 pounds of load on the unit of decking closest to the end of the longer span. The purpose of this load is to minimize uplift of that end of the bridge. The deflection caused by this load is not measured.

If deflection targets are on the decking rather than on the decking support, clamp the decking to the decking support at the targets to assure contact during initialization of measurements.

Either initialize the measuring devices to zero or record the initial readings. If the decking was clamped to the decking support, remove the clamp on the shorter span after initialization.

Uniformly distribute load on the unit of decking on the shorter span, as shown in the figure titled "Load Test 2."

As the 1000 pound load is being placed on the shorter span, observe sway and deflection. Stop loading and disqualify the bridge if

- sway at either sway target exceeds 1/2 inch, or
- vertical deflection at either deflection target exceeds 2 inches, or
- any part of the bridge, other than its bearing plates, comes to bear on the floor, or
- the decking falls off the decking support.

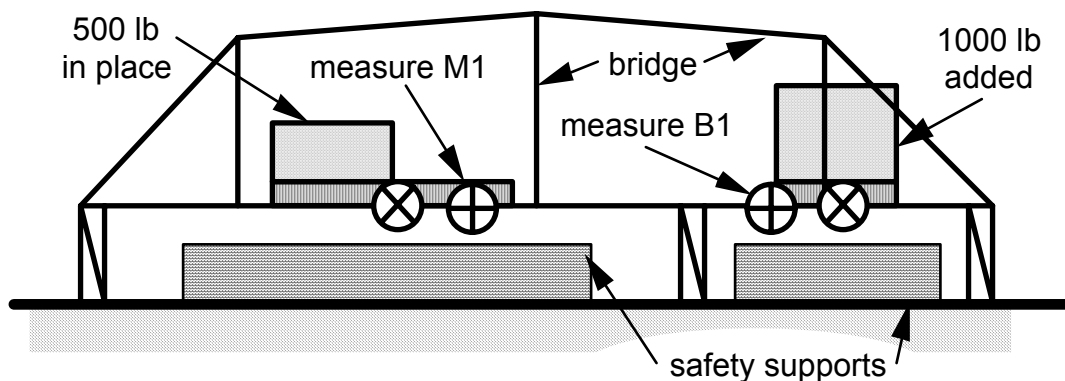

Load Test 2 (Side View)

If the 1000 pounds of load (in addition to decking) was successfully placed on the shorter span without exceeding sway or deflection limits, record the following measurements:

B1 = absolute value of the vertical distance of the deflection target on the shorter span from its position before any load was placed on the shorter span.

M1 = absolute value of the vertical distance of the deflection target on the longer span from its position before any load was placed on the shorter span.

If a sway or deflection limit was exceeded, remove all load and disqualify the bridge. Do not proceed to the next test.

In preparation for the next load test, record the vertical deflection at the target on the long span.

F. Load Test 3 - Longer Span

If the decking was clamped to the decking support, remove the clamp on the longer span.

With the 500 pound load remaining in place on the longer span and the 1000 pound load remaining in place on the shorter span, uniformly distribute additional load over the units of decking on the longer span as shown in the figure titled "Load Test 3."

As the load is being placed, observe sway and deflection. Stop loading and disqualify the bridge if

- a. sway at either sway target exceeds 1/2 inch measured from the position at the beginning of load test 2, or
- b. vertical deflection at either deflection target exceeds 2 inches measured from the position at the beginning of load test 2, or
- c. any part of the bridge, other than its bearing plates, comes to bear on the floor, or
- d. the decking falls off the decking support.

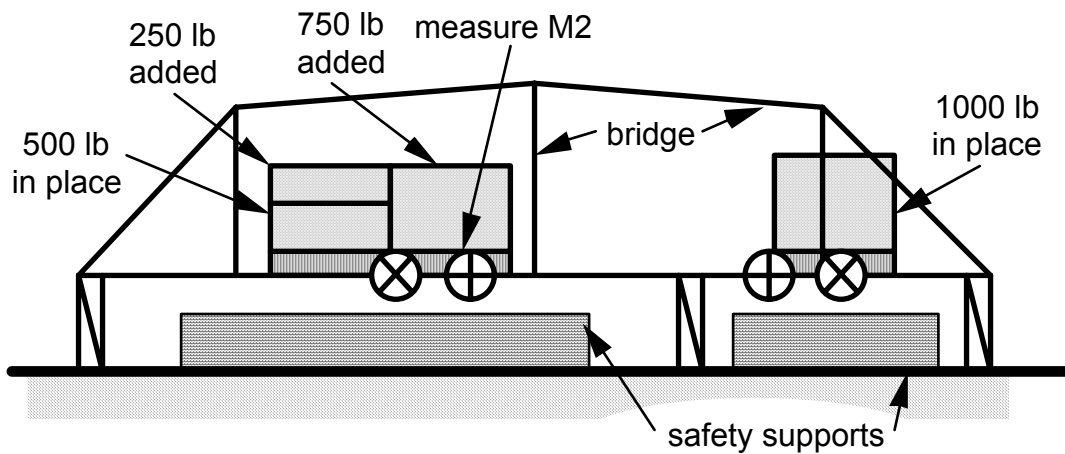

Load Test 3 (Side View)

If the additional 1000 pounds of load (in addition to decking) was successfully placed on the longer span without exceeding sway or deflection limits, record the following measurement:

M2 = absolute value of the vertical distance of the deflection target on the longer span from its position at the end of load test 2 but before any of the additional 1000 pound load was placed on the longer span. That is, M2 measures deflection of the longer span that occurred during load test 3 while the additional load was being placed on the longer span.

If a sway or deflection limit was exceeded, remove all load and disqualify the bridge.

G. Unloading

The bridge must be disqualified if it collapses during unloading.

H. Computing Aggregate Deflection

Compute and record: Aggregate deflection = $B1 + (5 \times M1) + M2$

XII. EQUIPMENT PROVIDED BY HOST

A complete list of hosting equipment appears in the *Guide for Hosts and Judges* which is distributed to host universities as a separate document. The following partial list is intended to help competitors know what to expect. Competitors should acquire similar equipment for use in practice and testing before the competition.

A. Lateral Load Device

Capable of applying 50 pound force in the horizontal direction.

B. Equipment for Measuring Sway

Sway is horizontal translation and is measured at two points by any accurate method. A suggested method is to suspend plumb bobs from the sway target points and measure sway from points marked on the ground.

C. Equipment for Measuring Deflection

Deflection is vertical translation and is measured at two points by any accurate method.

D. Decking

Preferred decking is steel bar grating identified as W-19-4 (1 x 1/8). The dimensions of a unit of grating are approximately 3'6" x 2'11-3/4" x 1" and the weight is approximately 50 pounds. However, the host may provide a different type of decking with the same dimensions. Grating has significant bending strength only in the direction of the main bars, which are 3'6" long. The grating will be installed with the main bars perpendicular to the length of the bridge, creating a roadway that is 3'6" wide. Therefore, support for the grating is needed for the edges that are parallel to the length of the bridge, but not for the edges of the grating that are perpendicular to the length.

E. Load

2500 pounds total. The load should be supplied in uniform pieces of size and weight that may be handled safely. When in place, the load should not provide significant stiffness in the longitudinal direction of the bridge. The recommended load consists of 25-pound lengths of 5 x 5 x 5/16 steel angle placed perpendicular to the length of the bridge. Sacks of material, containers of liquid, concrete blocks or jacking systems could be used. Decking is not included as part of the 2500 pound load.

F. Safety Supports

The safety supports must be used during load testing and are intended to limit the consequences of a bridge collapsing. The safety supports should be of sufficient height, strength, number and extent so that none of the load will fall more than four inches if the bridge collapses. Safety supports may be steel, timbers, sand bags or masonry units.

G. Floor

In both the construction site and loading area the surfaces on which the bridges will bear (river banks and island) should be as nearly co-planar as possible. If necessary, the host will build up parts of the floor with steel plates to reduce the deviation from plane to less than 1/4 inch.

XIII. INTERPRETATION OF RULES

Competitors, judges and host personnel who have questions are requested to consult web site <http://www.aisc.org/steelbridge.html> and to reread this *Rules* booklet carefully in its entirety. If questions remain unanswered, they may be submitted by e-mail to Mr. Fromy Rosenberg (rosenberg@aisc.org). Questions and answers will be posted on the web site.

XIV. JUDGING

The host will recruit judges. Judges are empowered to halt any activity that they deem to be hazardous. Judges have full authority over conduct of the competition and interpretation of the rules. Decisions, scoring, rating and disqualification are the sole responsibility of the judges and will be final. The host will assure that the judges are fully informed of the rules and procedures, and fully equipped for their tasks. The host and judges will follow directions in the *Guide for Hosts and Judges* provided by AISC.

XV. PROTESTS AND APPEALS

A. Before the Contest

Each team will designate a student as team captain. The host will identify the head judge.

B. During the Contest

A penalty, disqualification, measurement, score, or condition of competition may be protested only by a team captain and only to the head judge. The protest must be made as soon as possible after the situation becomes apparent. The head judge will not hear the protest if he or she is approached by students other than the team captain. As soon as possible after a protest is made, the head judge will interrupt the contest if necessary, gather the other judges and the captains of the teams involved, and hear the protest. The decision of the head judge is final.

Participants are reminded that civility and ethical behavior are expected during the contest and particularly concerning protests.

C. After the Regional Contest

If a team wants to appeal the decision of the head judge regarding a protest it may do so in an e-mail message to Mr. Fromy Rosenberg (rosenberg@aisc.org) followed by a letter mailed to Mr. Rosenberg (AISC, Suite 3100, One E. Wacker Dr., Chicago, IL 60601-2001) with a copy mailed to ASCE Student Activities Coordinator (ASCE, 1801 Alexander Bell Dr., Reston, VA 20191-4400). The letter should include the name of the college or university making the appeal; the names, addresses and telephone numbers of the faculty adviser and one team member; brief description of

the problem, the action taken at the contest to deal with it, and the action that the appealing team feels should have been taken; and computation showing how the appealing team's rankings would have been improved if a different action had been taken.

Appeals must be made by e-mail followed by letter. An appeal will be considered only if both the e-mail and the letter are received within one week after the regional contest.

The only redress that may be made is an invitation to participate in the national competition if the Rules Committee is convinced that the appeal is valid and that the appealing team should have qualified. Decisions and rankings made by regional judges will not be overturned.

D. After the National Contest

Appeals will not be accepted. However, AISC welcomes written suggestions for improving future competitions.

XVI. TIPS FOR COMPETITORS

1. Strive for challenging but realistic goals for design and construction. The following statistics from the 2002 National Student Steel Bridge Competition suggest the levels of performance that are possible. However, when reviewing these statistics keep in mind that the rules and scoring for 2003 differ from those for 2002.

	Winning bridge in category	Winning bridge, overall
Weight (pounds)	114	158
Construction time (minutes)	1.47	2.45
Aggregate deflection (inches)	0.81	1.54

2. Start work on the design early, leaving adequate time to procure materials, fabricate the bridge, load test it and practice construction.

3. Design a bridge that may be fabricated, erected and load tested safely, using available materials, tools and facilities.

4. Structural analysis may fail to disclose instability, such as buckling of slender compression members, sway, and torsion of under-deck trusses of triangular cross-section.

5. Design a bridge that accommodates imperfect field conditions such as uneven floor, non-standard load, and non-standard or bent decking.

6. Allow tolerances for all limiting dimensions in order to accommodate imprecise measurement, fabrication, thermal expansion, elastic and inelastic deformation, wear, etc. For example, if a bridge is required to provide at least 12

inches of clearance, and it is designed to provide exactly that clearance, then there is a high probability that the actual as-built clearance will be less than the specified minimum, resulting in a penalty. That probability of error may be reduced by designing the bridge to provide more than the required minimum clearance.

7. When fabricating your bridge, use safe tools, operate them carefully and with adequate supervision.

8. Follow all safety regulations and guidelines during construction practice and loading.

9. When practicing construction, wear hardhats and safety glasses or goggles both for safety and to accustom yourself to contest conditions.

10. It is strongly recommended that bridges be load tested before competition, if it can be done safely, so that weaknesses and instability can be corrected.

11. When load testing your bridge use safety supports under the decking, sufficient in height, strength, number and extent to minimize the distance the load will drop if the bridge collapses. This will reduce risk of injury and limit damage to the bridge if it collapses. Keep hands and feet out from under the bridge.

12. When load testing your bridge wear hardhats, safety glasses or goggles, gloves and leather construction boots.

13. Don't stand, sit or lie on your bridge.

14. To expedite the competition have a preset plan for unloading and staging components of your bridge.

15. The island and river banks at the contest should be within 1/4 inch of co-planar. If your bridge will be adversely affected by larger deviations from planarity you should take some thin steel sheets to the contest to help with fine adjustments.

16. When packing for the competition, remember to bring hardhats, safety glasses or goggles, gloves and construction boots.

XVII. SCORE SHEET

A. Construction Speed and Time Penalties

Clock time = _____ minutes

Repair time, see "X.I Construction: Repairs"

_____ x 1.5 = + _____ minutes

Time penalties, see "X.G Construction: Accidents"

item 1: violations _____ x 1 = + _____ minutes

items 2,3,4: violations _____ x 1/2 = + _____ minutes

item 5: violations _____ x 1/3 = + _____ minutes

items 6,7: violations _____ x 1/6 = + _____ minutes

Time penalty, see "XI.B Load Tests: Damage" + _____ minutes

CONSTRUCTION TIME (add) = _____ minutes
Lowest time wins.

B. Lightness and Weight Penalties

Bridge weight = _____ pounds

Weight penalties, see "VIII.B Dimensions and Support: Usability"

Number violations = 1 inch _____ x 100 pounds = + _____ pounds

Number violations 1 - 2 inch _____ x 300 pounds = + _____ pounds

Number violations 2 - 3 inch _____ x 600 pounds = + _____ pounds

See "IX.B Material & Components: Durability & Constructability"

Number of violations _____ x 10 pounds = + _____ pounds

Wt. of parts in violation _____ pounds x 5 = + _____ pounds

TOTAL WEIGHT (add) = _____ pounds
Lowest weight wins.

C. Aesthetics

Full name of college or university appears on bridge or on attached banner or placard in letters at least 2 inches high.

Poster describing design and fabrication, no larger than 2 x 3 feet.

Other items that may be considered:

General appearance

Balance and proportion

Finish

Elegance

Judges should not declare ties in aesthetics

AESTHETICS SCORE = _____

D. Stiffness

AGGREGATE DEFLECTION: $B1 + (5 \times M1) + M2 =$ _____ inches
Lowest deflection wins.

E. Construction Economy

Number builders _____ x Const. Time (part A) _____ x 100 = _____ thousand \$
 $C_c =$ CONSTRUCTION COST = _____ thousand \$
Lowest cost wins.

F. Structural Efficiency

$W =$ larger of total weight (part B) or 100 = _____ pounds
 $\Delta =$ larger of aggregate deflection (part D) or 1.00 = x _____ inches
 $D =$ larger of (maximum height - 18) or
(18 - minimum clearance) or 24 = x _____ inches
 $C_s =$ STRUCTURAL COST (multiply) = _____ thousand \$
Lowest cost wins.

G. Overall Performance

C_c (from part E) _____ + C_s (from part F) _____ = _____
Lowest total wins.

H. Ranks

Disqualified bridges will not be ranked.

Aesthetics is the tie-breaker for all categories

Construction Speed _____ Lightness _____
Aesthetics _____ Stiffness _____
Construction Economy _____ Structural Efficiency _____
Overall Performance _____

_____ This Score Sheet implements section "VI Scoring."